

1-111



STANDARD STEILKEGELAUFNAHMEN UND ZUBEHÖR
STANDARD TOOLHOLDERS AND ACCESSORIES
MANDRINS STANDARD ET ACCESSOIRES
MANDRINI STANDARD ED ACCESSORI

113-168



HSK
(DIN 69893)

169-188



SCHRUMPFUTTER
SHRINK FIT CHUCKS
MANDRINS DE FRETTAGE
MANDRINI A CALETTAMENTO

189-264



WERKZEUGHALTER FÜR CNC-DREHEMASCHINEN
TOOLHOLDERS FOR CNC LATHES
PORTE-OUTILS POUR TOURS CNC
PORTAUTENSILI PER TORNII CNC

265-309



KLEMMHALTER/BOHRSTANGEN
TURNING TOOLS
PORTE-PLAQUETTES
PORTAINSERI

311-349



HSK KLEMMHALTER UND WERKZEUGHALTER (NACH DIN 69893)
HSK HOLDERS AND TOOLHOLDERS (DIN 69893)
OUTILS ET PORTE-OUTILS AVEC ATTACHEMENT HSK (DIN 69893)
UTENSILI E PORTAUTENSILI CON ATTACCO HSK (DIN 69893)

351-371



FRÄSER MIT WENDESCHNEIDPLATTEN
WENDENPLATTEN-VOLLBOHER FÜR BEARBEITUNGSZENTRUM
MILLING CUTTERS WITH INDEXABLE INSERTS
WORKING CENTER HIGH SPEED DRILLS
FRAISES À FIXAGE MÉCANIQUE
FORET A PLAQUETTES POUR CENTRE D'USINAGE
FRESE A FISSAGGIO MECCANICO
PUNTE AD INSERTI PER CENTRI DI LAVORO

The logo for KINTEK, featuring the word "KINTEK" in a bold, sans-serif font. The letter "K" is white with red arrowheads pointing outwards from its top and bottom horizontal bars. The remaining letters "INTEK" are white.

La sfida sui mercati mondiali dei prossimi anni porrà la necessità, per le aziende, di eccezionali performances produttive e commerciali. Kintek è pronta!



Le défi dans les marchés mondiaux portera dans le prochaines années la nécessité, pour les entreprises, d'exceptionnelles performances soit productives soit commerciales. Kintek est prête!



The challenge on the world markets for next years will compel companies to arrange for exceptional productive commercial performances. Kintek is Ready!



Die Herausforderung auf den Markt in den nächsten Jahren wird sonder Herstellungs-Handelsperformances zu gewinnen. Kintek ist bereit!

STANDARD STEILKEGELAUFNAHMEN UND ZUBEHÖR

STANDARD TOOLHOLDERS AND ACCESSORIES

MANDRINS STANDARD ET ACCESSOIRES

MANDRINI STANDARD ED ACCESSORI



SUMMARY

DRILL

INHALTSVERZEICHNIS

SOMMAIRE

FORN



DIN 2080

PAGINE **1** **15**



DIN 69871

PAGINE **17** **45**



MAS/BT

PAGINE **47** **74**



ACCESSORIES

PAGINE **75** **103**



KIT

PAGINE **105** **109**

DATI TECNICI
TECHNICAL
INFORMATION

PAGINE **110** **111**



DIN 2080

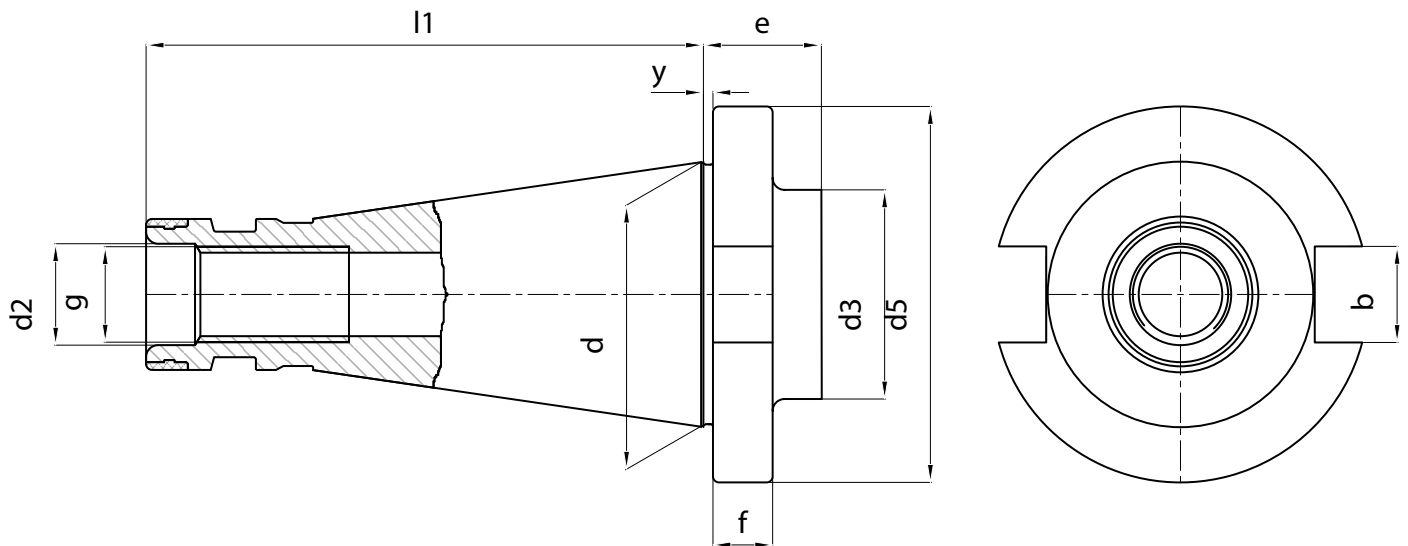

ISO	d	l1	d2	g	y	d5	f	d3	e	b
30	31,75	68,4	13	M12	1,6	50	8	36	18,6	16,1
40	44,45	93,4	17	M16	1,6	63	10	50	22,6	16,1
50	69,85	126,8	26	M24	3,2	97,5	12	78	31,2	25,7

ZYLINDERSCHAFTAUFNAHME WELDON
END MILL HOLDERS WELDON
MANDRINS POUR OUTIL TYPE WELDON
MANDRINI PORTAFRESE TIPO WELDON

DIN 1835 B

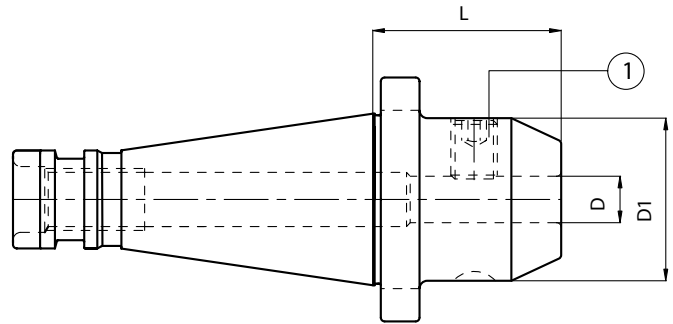

Code N.	Description	ISO	D	L	D1
213-11102	ISO40H50WE06	40	6	50	25
213-11103	ISO40H50WE08	40	8	50	28
213-11104	ISO40H50WE10	40	10	50	35
213-11105	ISO40H50WE12	40	12	50	42
213-11106	ISO40H50WE14	40	14	50	44
213-11107	ISO40H63WE16	40	16	63	48
213-11108	ISO40H63WE18	40	18	63	50
213-11109	ISO40H63WE20	40	20	63	52
213-11110	ISO40H90WE25	40	25	90	65
213-11111	ISO40H90WE32	40	32	90	72
213-11112	ISO50H50WE06	50	6	50	25
213-11113	ISO50H50WE08	50	8	50	28
213-11114	ISO50H63WE10	50	10	63	35
213-11115	ISO50H63WE12	50	12	63	42
213-11116	ISO50H63WE14	50	14	63	44
213-11117	ISO50H63WE16	50	16	63	48
213-11118	ISO50H63WE18	50	18	63	50
213-11119	ISO50H63WE20	50	20	63	52
213-11120	ISO50H80WE25	50	25	80	65
213-11121	ISO50H85WE32	50	32	85	72
213-11122	ISO50H95WE40	50	40	95	78

Ersatzteile / Spare parts / Pieces detachees / Componenti

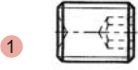
D	Locking screw	Quantity
		
6	811-106001	1
8	811-106002	1
10	811-106004	1
12	811-106005	1
14	811-106005	1
16	811-106006	1
18	811-106006	1
20	811-106007	1
25	811-106008	2
32	811-106009	2
40	811-106009	2

ZYLINDERSCHAFTAUFNAHME WHISTLE NOTCH
END MILL HOLDERS WHISTLE NOTCH
MANDRINS POUR OUTIL TYPE WHISTLE NOTCH
MANDRINI PORTAFRESE TIPO WHISTLE NOTCH

DIN 1835 E

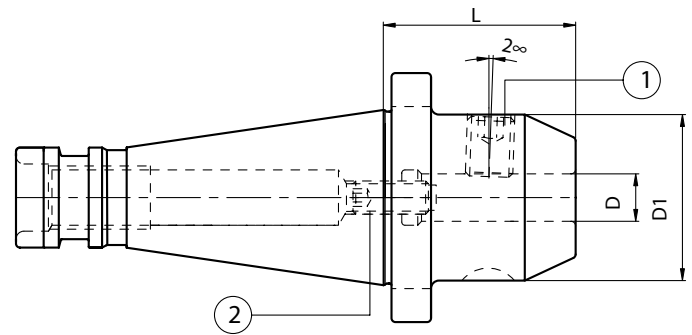

Code N.	Description	ISO	D	L	D1
213-31102	ISO40H50WN06	40	6	50	25
213-31103	ISO40H50WN08	40	8	50	28
213-31104	ISO40H50WN10	40	10	50	35
213-31105	ISO40H50WN12	40	12	50	42
213-31106	ISO40H50WN14	40	14	50	44
213-31107	ISO40H63WN16	40	16	63	48
213-31108	ISO40H63WN18	40	18	63	50
213-31109	ISO40H63WN20	40	20	63	52
213-31110	ISO40H90WN25	40	25	90	65
213-31111	ISO40H90WN32	40	32	90	72
213-31112	ISO50H50WN06	50	6	50	25
213-31113	ISO50H50WN08	50	8	50	28
213-31114	ISO50H63WN10	50	10	63	35
213-31115	ISO50H63WN12	50	12	63	42
213-31116	ISO50H63WN14	50	14	63	44
213-31117	ISO50H63WN16	50	16	63	48
213-31118	ISO50H63WN18	50	18	63	50
213-31119	ISO50H63WN20	50	20	63	52
213-31120	ISO50H80WN25	50	25	80	65
213-31121	ISO50H85WN32	50	32	85	72
213-31122	ISO50H95WN40	50	40	95	78

Ersatzteile / Spare parts / Pieces detachees / Componenti

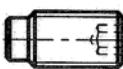
D	Locking screw	Quantity	Stop screw	Quantity
				
6	811-106001	1	811-104008	1
8	811-106002	1	811-104014	1
10	811-106004	1	811-104022	1
12	811-106005	1	811-104030	1
14	811-106005	1	811-104030	1
16	811-106006	1	811-104037	1
18	811-106006	1	811-104037	1
20	811-106007	1	811-104037	1
25	811-106008	2	811-104046	1
32	811-106009	2	811-104046	1
40	811-106009	2	811-104046	1

**KOMBI-AUFSTECKFRÄSDORNE
COMBI-SHELL MILL ADAPTORS
MANDRINS PORTE-FRAISES A DOUBLE USAGE
MANDRINI PORTAFRESE COMBINATI**

DIN 6358

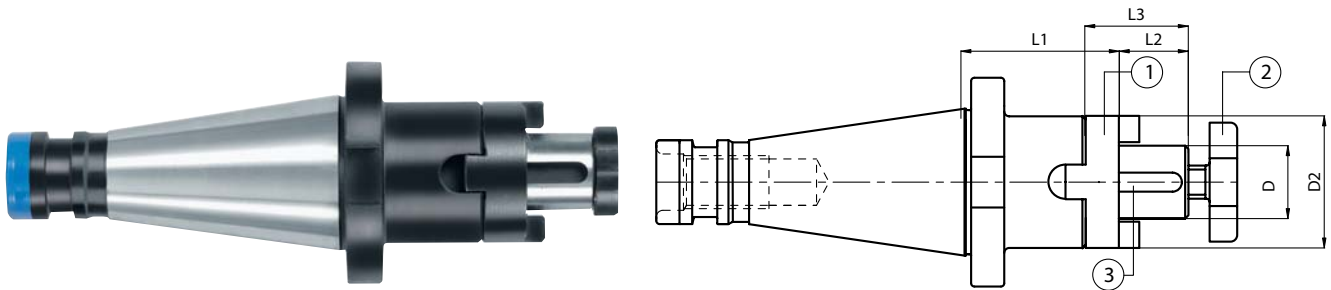

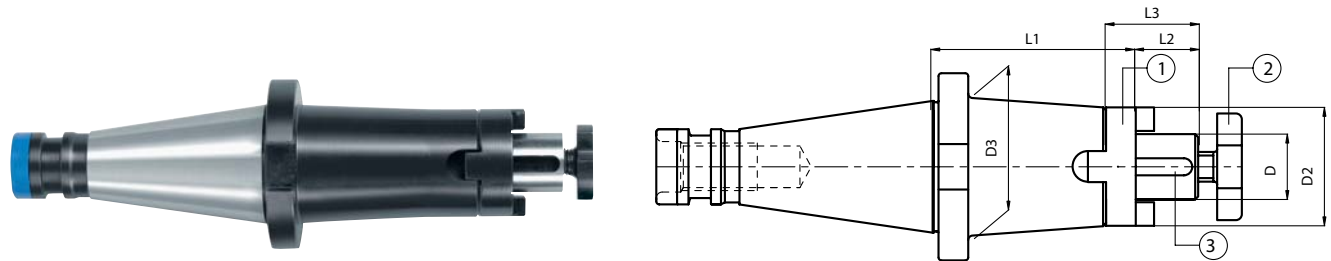

	Code N.	Description	ISO	D	L1	L2	L3	D2
STANDARD	216-11101	ISO40H52D16C	40	16	52	17	27	32
	216-11102	ISO40H52D22C	40	22	52	19	31	40
	216-11103	ISO40H52D27C	40	27	52	21	33	48
	216-11104	ISO40H52D32C	40	32	52	24	38	58
	216-11105	ISO40H52D40C	40	40	52	27	41	70
	216-11106	ISO50H55D16C	50	16	55	17	27	32
	216-11107	ISO50H55D22C	50	22	55	19	31	40
	216-11108	ISO50H55D27C	50	27	55	21	33	48
	216-11109	ISO50H55D32C	50	32	55	24	38	58
	216-11110	ISO50H55D40C	50	40	55	27	41	70



	Code N.	Description	ISO	D	L1	L2	L3	D2	D3
EXTENDED	216-11120	ISO40H90D16C	40	16	90	17	27	32	40
	216-11121	ISO40H90D22C	40	22	90	19	31	40	44
	216-11122	ISO40H90D27C	40	27	90	21	33	48	-
	216-11123	ISO40H100D32C	40	32	100	24	38	58	-
	216-11125	ISO50H100D16C	50	16	100	17	27	32	50
	216-11126	ISO50H100D22C	50	22	100	19	31	40	60
	216-11127	ISO50H100D27C	50	27	100	21	33	48	60
	216-11128	ISO50H100D32C	50	32	100	24	38	58	-
	216-11129	ISO50H100D40C	50	40	100	27	41	70	-

Ersatzteile / Spare parts / Pieces detachees / Componenti

D	Ring	Screw	Key
			
16	814-30001	811-107003	814-201010
22	814-30002	811-107004	814-201020
27	814-30003	811-107005	814-201030
32	814-30004	811-107006	814-201040
40	814-30005	811-107007	814-201050

AUFSTECKFRÄSDORNE FÜR FRÄSER MIT QUERNUT
FACE MILL HOLDERS-TENONS DRIVE
MANDRINS PORTE-FRAISE-ENTRAÎNEMENT PAR TENONS
MANDRINI PORTAFRESE A TRASCINAMENTO FISSO

ISO 3937

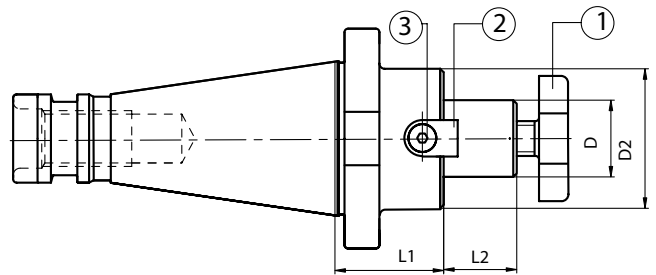

Code N.	Description	ISO	D	L1	L2	D2	
STANDARD	216-71105	ISO40H45D16F	40	16	45	17	38
	216-71106	ISO40H45D22F	40	22	45	19	48
	216-71107	ISO40H45D27F	40	27	45	21	58
	216-71108	ISO40H50D32F	40	32	50	24	78
	216-71109	ISO40H55D40F	40	40	55	27	88
	216-71115	ISO50H45D16F	50	16	45	17	38
	216-71116	ISO50H45D22F	50	22	45	19	48
	216-71117	ISO50H45D27F	50	27	45	21	58
	216-71118	ISO50H50D32F	50	32	50	24	78
216-71119	ISO50H50D40F	50	40	50	27	88	

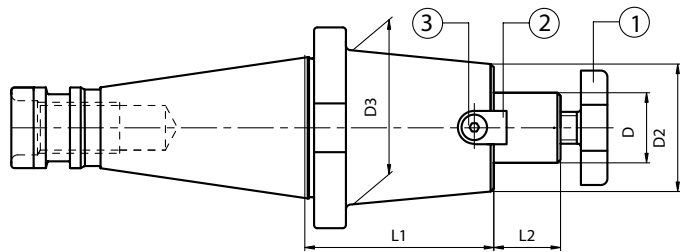

Code N.	Description	ISO	D	L1	L2	D2	D3	
EXTENDED	216-71141	ISO40H120D16F	40	16	120	17	32	39
	216-71142	ISO40H120D22F	40	22	120	19	40	49
	216-71143	ISO40H120D27F	40	27	120	21	48	60
	216-71144	ISO40H120D32F	40	32	120	24	58	62
	216-71145	ISO50H150D16F	50	16	150	17	32	39
	216-71146	ISO50H150D22F	50	22	150	19	40	49
	216-71147	ISO50H150D27F	50	27	150	21	48	75
	216-71148	ISO50H150D32F	50	32	150	24	58	80
	216-71149	ISO50H150D40F	50	40	150	27	70	90

Ersatzteile / Spare parts / Pieces detachees / Componenti

D/D2	Screw	Tenon	Screw
16/32	811-107003	814-20214	811-101003
16/38	811-107003	814-20228	811-101004
22/40	811-107004	814-20215	811-101010
22/48	811-107004	814-20225	811-101011
27/48	811-107005	814-20216	811-101017
27/58	811-107005	814-20227	811-101018
32/58	811-107006	814-20217	811-101027
32/78	811-107006	814-20263	811-101029
40/70	811-107007	814-20218	811-101028
40/88	811-107007	814-20271	811-101029

AUFSTECKFRÄSERDORNE FÜR MESSERKÖPFE
FACE MILL HOLDER FOR FACE MILLING CUTTERS
MANDRINS PORTE-FRAISE POUR FRAISES A SURFACER
MANDRINI PORTAFRESE PER FRESE A SPIANARE

DIN 6357

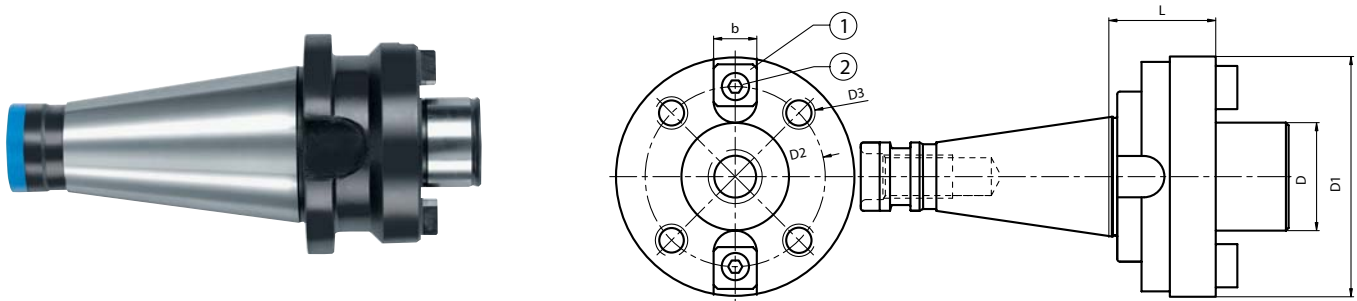

Code N.	Description	ISO	D	L	D1	D2	D3	b
216-21101	ISO40H46.6D40	40	40	46.6	89	66.7	M12	15.9
216-21102	ISO50H53.2D40	50	40	53.2	89	66.7	M12	15.9
216-21104	ISO50H70.2D60	50	60	70.2	129	101.6	M16	25.4

Ersatzteile / Spare parts / Pieces detachees / Componenti

D	Tenon	Screw
	1	2
40	814-202080	811-101028
60	814-202120	811-101063

ZWISCHENHÜSEN FÜR MORSEKEGEL MIT AUSTREIBBLAPPEN
MORSE TAPER ADAPTORS FOR DRILLS
DOUILLES POUR CONE MORSE A TENON
MANDRINI PORTAPUNTE ATTACCO CONO MORSE

DIN 228-2 FORM D

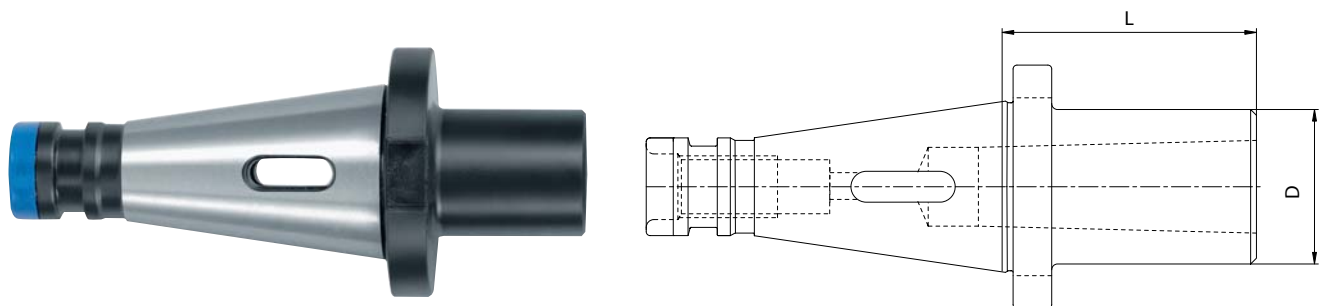

Code N.	Description	ISO	MORSE	D	L
212-41101	ISO40H50CM1P	40	1	25	50
212-41102	ISO40H50CM2P	40	2	32	50
212-41103	ISO40H65CM3P	40	3	40	65
212-41104	ISO40H95CM4P	40	4	48	95
212-41111	ISO50H45CM1P	50	1	25	45
212-41105	ISO50H60CM2P	50	2	32	60
212-41106	ISO50H65CM3P	50	3	40	65
212-41107	ISO50H70CM4P	50	4	48	70
212-41108	ISO50H105CM5P	50	5	63	105

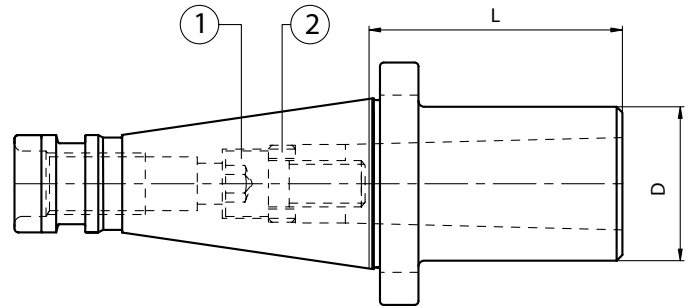

ZWISCHENHÜLSEN FÜR MORSEKEGEL MIT ANZUGSGEWINDE
MORSE TAPER ADAPTER WITH TREAD
DOULLES POUR CONE MORSE AVEC TARAUDAGE
MANDRINI PORTAFRESE ATTACCO CONO MORSE

DIN 228-2 FORM C

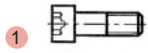

Code N.	Description	ISO	MORSE	D	L
212-21101	ISO40H50CM1F	40	1	25	50
212-21102	ISO40H50CM2F	40	2	32	50
212-21103	ISO40H65CM3F	40	3	40	65
212-21104	ISO40H95CM4F	40	4	48	95
212-21111	ISO50H45CM1F	50	1	25	45
212-21105	ISO50H60CM2F	50	2	32	60
212-21106	ISO50H65CM3F	50	3	40	65
212-21107	ISO50H65CM4F	50	4	48	65
212-21108	ISO50H120CM5F	50	5	63	120

Ersatzteile / Spare parts / Pieces detachees / Componenti

ISO/MORSE	Screw	Ring
		
40/1	811-101029	811-302030
40/2	811-111007	811-302031
40/3	811-101065	811-302032
40/4	811-111005	811-302036
50/1	811-101029	811-302030
50/2	811-101054	811-302032
50/3	811-101065	811-302032
50/4	811-401037	811-302036
50/5	811-101092	811-302034

ZWISCHENHÜLSEN FÜR MORSEKEGEL MIT AUSTREIBBLAPPEN ODER ANZUGSGEWINDE
MORSE TAPER ADAPTORS FOR DRILLS AND MILLS
DOUILLES POUR CONE MORSE A TENON ET AVEC TARAUDAGE
MANDRINI PORTAPUNTE-PORTAFRESE ATTACCO CONO MORSE

DIN 228-2 FORM C/D

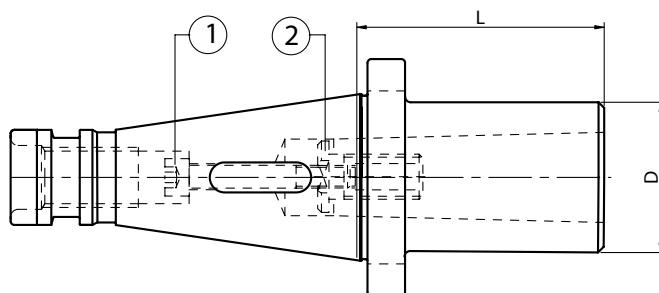

	Code N.	Description	ISO	MORSE	D	L
STANDARD	212-61101	ISO40H50CM1P/F	40	1	25	50
	212-61102	ISO40H50CM2P/F	40	2	32	50
	212-61103	ISO40H65CM3P/F	40	3	40	65
	212-61105	ISO50H45CM1P/F	50	1	25	45
	212-61106	ISO50H60CM2P/F	50	2	30	60
	212-61107	ISO50H65CM3P/F	50	3	36	65
	212-61108	ISO50H65CM4P/F	50	4	48	65
	212-61109	ISO50H100CM5P/F	50	5	63	100

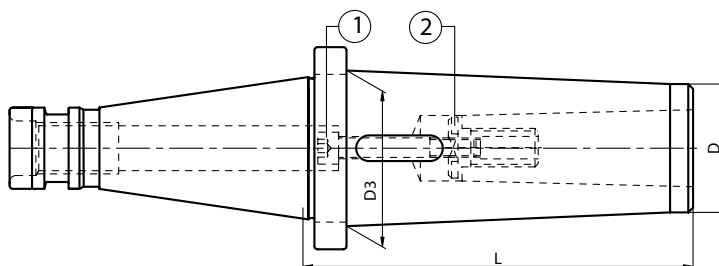

	Code N.	Description	ISO	MORSE	D	D3	L
EXTENDED	212-61114	ISO40H115CM1P/F	40	1	18	25	115
	212-61115	ISO40H125CM2P/F	40	2	25	32	125
	212-61116	ISO40H140CM3P/F	40	3	33	40	140
	212-61117	ISO50H120CM1P/F	50	1	18	25	120
	212-61118	ISO50H140CM2P/F	50	2	25	32	140
	212-61119	ISO50H150CM3P/F	50	3	33	40	150
	212-61120	ISO50H180CM4P/F	50	4	40	48	180
	212-61121	ISO50H220CM5P/F	50	5	55	63	220

Ersatzteile / Spare parts / Pieces detachees / Componenti

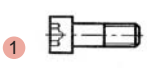
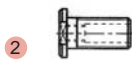
ISO/MORSE	Screw	Ring
		
40/1	811-101033	-
40/2	811-401018	-
40/3	811-101034	811-302006
50/1	811-101033	-
50/2	811-101058	-
50/3	811-101069	-
50/4	811-401016	-
50/5	811-101071	811-302008

**ZWISCHENHÜLSEN SK X HSK - HAND SPANNSYSTEM
TAPER ADAPTER SA X HSK - MANUAL CLAMPING
DOUILLES INTERMEDIAIRES SA X HSK - SERRAGE MANUEL
MANDRINI RIDUZIONE DA ISO A HSK - CHIUSURA MANUALE**

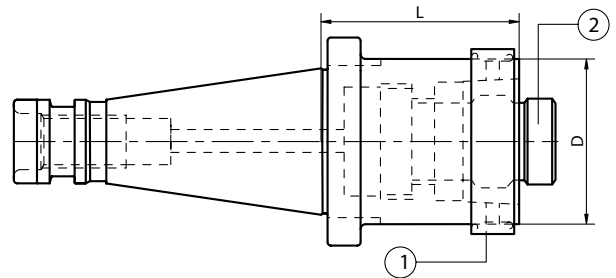

Code N.	Description	ISO	HSK	D	L	① Ring (complete)	② Locking unit (complete)
212-91106	ISO40H50HSK40A	40	40	40	50	H40A-AN	H40A-UBL
212-91101	ISO40H60HSK50A	40	50	50	60	H50A-AN	H50A-UBL
212-91102	ISO40H80HSK63A	40	63	63	80	H63A-AN	H63A-UBL
212-91103	ISO50H50HSK50A	50	50	50	50	H50A-AN	H50A-UBL
212-91104	ISO50H60HSK63A	50	63	63	60	H63A-AN	H63A-UBL

**ZWISCHENHÜLSEN SK X SK
ISO TAPER ADAPTORS
DOUILLES INTERMEDIAIRES SA X SA
MANDRINI A RIDUZIONE DA ISO A ISO**

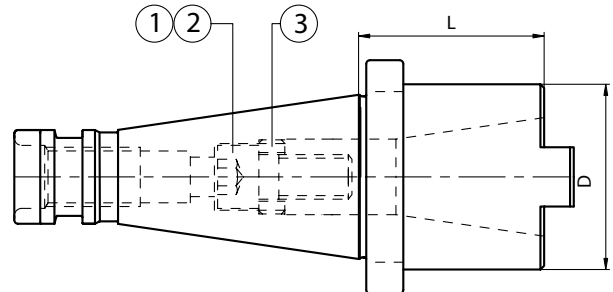

Code N.	Description	ISO	ISO	D	L
212-11102	ISO40H50ISO30/TC30	40	30	50	50
212-11111	ISO40H100ISO40/TC40	40	40	68	100
212-11101	ISO50H63ISO40/TC40	50	40	78	63
212-11112	ISO50H100ISO50/TC50	50	50	100	100

Ersatzteile / Spare parts / Pieces detachees / Componenti

ER/TR	Screw (ISO)	Screw (TC)	Ring	Wrench
	①	②	③	
40/30	811-101065	811-101069	811-302032	816-202060
40/40	811-401037	811-401055	811-302036	816-202070
50/40	811-401037	811-401055	811-302036	816-202070
50/50	811-401052	811-401135	811-302047	816-202090

Schraubenschlüssel und Verschlußschraube für DIN69871/MAS BT/DIN2080 werden mitgeliefert
 Supplied with a wrench and a screw DIN69871/MAS BT/DIN2080
 Livré avec une clé et une vis de serrage DIN69871/MAS BT/DIN2080
 In dotazione chiave e vite per chiusura DIN69871/MAS BT/DIN2080

**SPANNZANGENFUTTER ER TYP
ER COLLET CHUCKS
MANDRINS A PINCES TYPE ER
MANDRINI PORTAPINZA TIPO ER**

DIN 6499

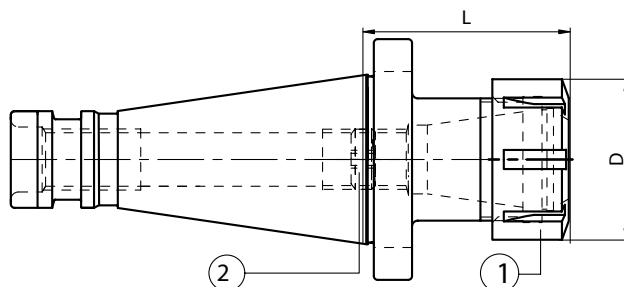

	Code N.	Description	ISO	ER	D	L
STANDARD	214-31105	ISO30H42ER16	30	16	28	42
	214-31106	ISO30H42ER25	30	25	45	42
	214-31107	ISO30H50ER32	30	32	50	50
	214-31101	ISO40H53ER25	40	25	45	53
	214-31102	ISO40H68ER32	40	32	50	68
	214-31114	ISO40H80ER40	40	40	63	80
	214-31137	ISO50H65ER25	50	25	45	65
	214-31103	ISO50H68ER32	50	32	50	68
	214-31104	ISO50H76ER40	50	40	63	76

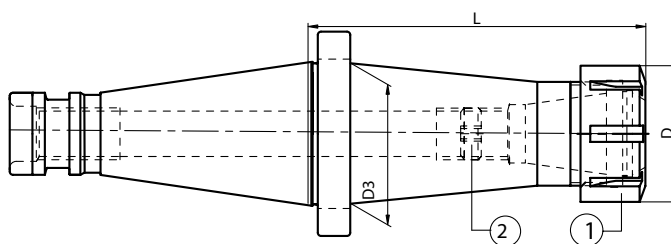

	Code N.	Description	ISO	ER	D	D3	L
EXTENDED	214-31108	ISO40H110ER25	40	25	45	44	110
	214-31109	ISO40H110ER32	40	32	50	50	110
	214-31138	ISO50H140ER25	50	25	45	44	140
	214-31110	ISO50H140ER32	50	32	50	50	140
	214-31111	ISO50H140ER40	50	40	63	60	140

Ersatzteile / Spare parts / Pieces detachees / Componenti

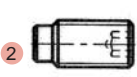
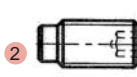
ER	Nut	Stop screw	Stop screw
			
16	812-203005	811-303119	-
25	812-203001	811-303121	-
ISO30/25	812-203001	-	811-303001
32	812-203002	811-303118	-
ISO30/32	812-203002	-	811-303001
40	812-203003	811-303122	-

**KRAFTSPANNFUTTER
MILLING CHUCK
MANDRINS A FORT SERRAGE
MANDRINI A FORTE SERRAGGIO**

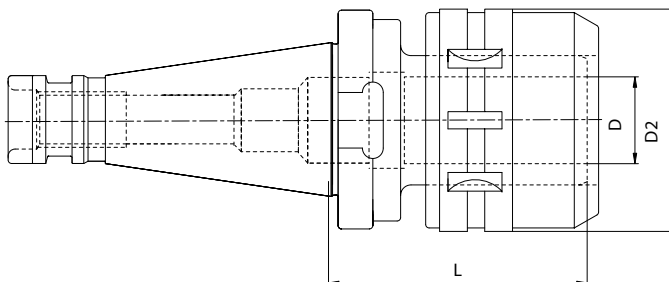

Code N.	Description	ISO	D	D2	L
214-01101	ISO40H83C32	40	32	72	83
214-01102	ISO50H85C32	50	32	72	85

**BOHRFUTTERAUFNAHMEN
ABORS FOR DRILL CHUCKS
ARBRES POUR MANDRINS DE PERCAGE
ATTACCO PER MANDRINI PORTAPUNTE**

DIN 238

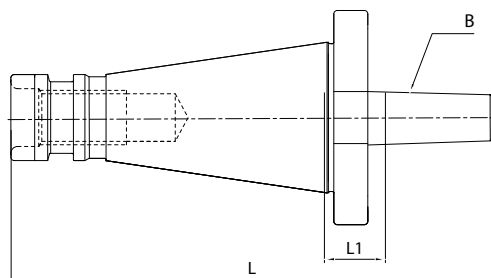

Code N.	Description	ISO	B	L	L1
216-31102	ISO40H17B16	40	16	134.4	17
216-31103	ISO40H17B18	40	18	142.4	17
216-31104	ISO50H20B16	50	16	170.8	20
216-31105	ISO50H20B18	50	18	178.8	20

**KURZBOHRFUTTER
UNIVERSAL DRILL CHUCKS
MANDRINS UNIVERSELS DE PERCAGE
MANDRINI PORTAPUNTE INTEGRALI**

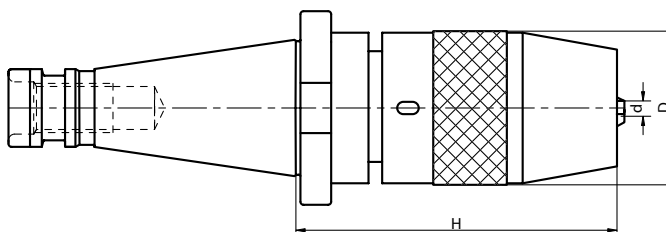

Code N.	Description	ISO	H	D	Clamping capacity	Wrench
252-11101	ISO40H105R1-13	40	105	50	1-13	816-152001
252-11102	ISO40H115R3-16	40	115	57	3-16	816-152002
252-11103	ISO50H105R1-13	50	105	50	1-13	816-152001
252-11104	ISO50H115R3-16	50	115	57	3-16	816-152002

RUNOUT ACCURACY 0.04 MM T.I.R.

Supplied with spanner wrench to allow the application of supplementary gripping torque.
DO NOT USE IN REVOLUTION IN COUNTER-CLOCKWISE DIRECTION.

PRECISIONE DI ROTAZIONE 0.04 MM

Per incrementare la forza di serraggio i mandrini sono forniti con chiave di bloccaggio.
NON DEVONO ESSERE USATI PER LAVORAZIONI CON ROTAZIONE A SINISTRA.

**KURZBOHRFUTTER FÜR RECHTS- UND LINKSLAUF
UNIVERSAL DRILL CHUCKS FOR LEFT AND RIGHT ROTATION
MANDRIN DE PERCAGE POUR ROTATION GAUCHE-DROITE
MANDRINI PORTAPUNTE INTEGRALI PER ROTAZIONE DESTRA E SINISTRA**

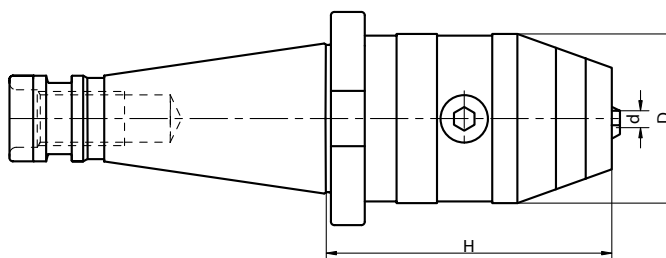

Code N.	Description	ISO	H	D	Clamping capacity	Wrench
252-11105	ISO40H85R1-13X	40	85	50	1-13	816-111024
252-11106	ISO40H90R3-16X	40	90	50	3-16	816-111025
252-11107	ISO50H85R1-13X	50	85	50	1-13	816-111024
252-11108	ISO50H90R3-16X	50	90	50	3-16	816-111025

RUNOUT ACCURACY 0.03 MM T.I.R.

Suitable for right and left rotation up to 7000 rpm. ○ With fine balancing and extra price, they can run up to 15000rpm.

PRECISIONE DI ROTAZIONE 0.03 MM.

Adatti per rotazione sia destra che sinistra, con velocità max di 7000 g/min.
Velocità fino a 15000 g/min. sono ottenibili previa bilanciatura fine e con aumento di prezzo.

**GEWINDESCHNEID-SCHNELLWECHSELFUTTER MIT LÄNGENAUSGLEICH
TENSION AND COMPRESSION TAPPING HEAD
MANDRINS DE TARAUDAGE A CHANGEMENT RAPIDE A DOUBLE USAGE
MASCHIATORI A DOPPIA COMPENSAZIONE**

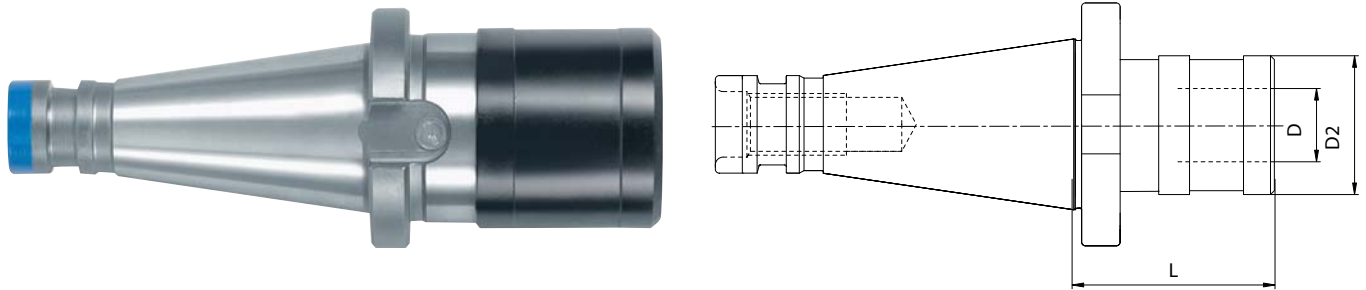

Code N.	Description	ISO	SIZE	Top range	PRESS.	EXT.	D	D2	L
M-1010	ISO30H50GR1DC	30	1	M3-M12	9	9	19	36	50
M-1020	ISO40H52GR1DC	40	1	M3-M12	9	9	19	36	52
M-1120	ISO40H77GR2DC	40	2	M6-M20	15	15	31	53	77
M-1130	ISO50H79GR2DC	50	2	M6-M20	15	15	31	53	79
M-1220	ISO40H118GR3DC	40	3	M14-M33	24	24	48	78	118
M-1230	ISO50H125GR3DC	50	3	M14-M33	24	24	48	78	125

**STELLHÜLENAUFNAHMEN
MASTER SHANKS FOR ADJUSTABLE ADAPTORS
MANDRINS POUR DOUILLES DE REGLAGE
MANDRINI PER ASTUCCI REGISTRABILI**

DIN 6327

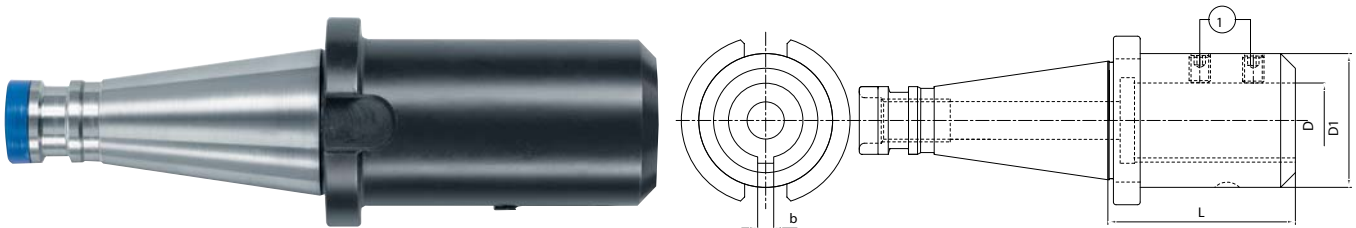

Code N.	Description	ISO	D	D1	L	b
211-11101	ISO40H100D28TR	40	28	50	100	6
211-11102	ISO40H120D36TR	40	36	63	120	8
211-11103	ISO50H100D28TR	50	28	50	100	6
211-11104	ISO50H100D36TR	50	36	63	100	8

Ersatzteile / Spare parts / Pieces detachees / Componenti

D	Screw
	
28	811-102027
36	811-102036

**ROHLINGE
BLANK TOOLHOLDER
BARRES D'ALEPAGE SEMI-FINIES
MANDRINI SEMILAVORATI A STELO TENERO**

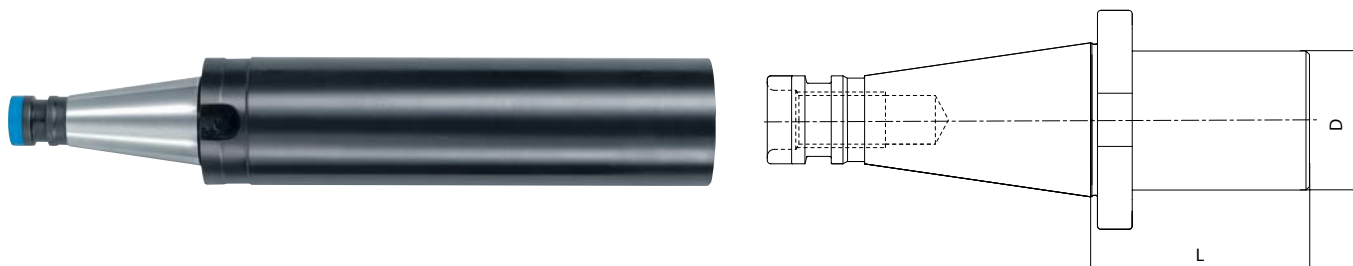

Code N.	Description	ISO	D	L
217-41101	ISO40H160D40.5SM	40	40.5	160
217-41102	ISO40H160D63.5SM	40	63.5	160
217-41103	ISO40H250D63.5SM	40	63.5	250
217-41104	ISO50H160D80SM	50	80	160
217-41105	ISO50H200D80SM	50	80	200
217-41106	ISO50H300D80SM	50	80	300

